

MAXAIR500™ SUBMERSIBLE AERATORS

WWW.MAXAIR500.COM



2-YEAR WARRANTY

The MAXAIR500™ Submersible Aerator is a superior choice for new installations or upgrading an existing submersible aerator.

Multi-Flo/EnviroGuard* alternative

The MAXAIR500 has durable corrosion resistant stainless steel legs with heavy duty rubber feet for solid stability in the tank.

The continuous duty maintenance free motor of the MAXAIR500 is fully enclosed in a stainless steel and powder coated outer shell.

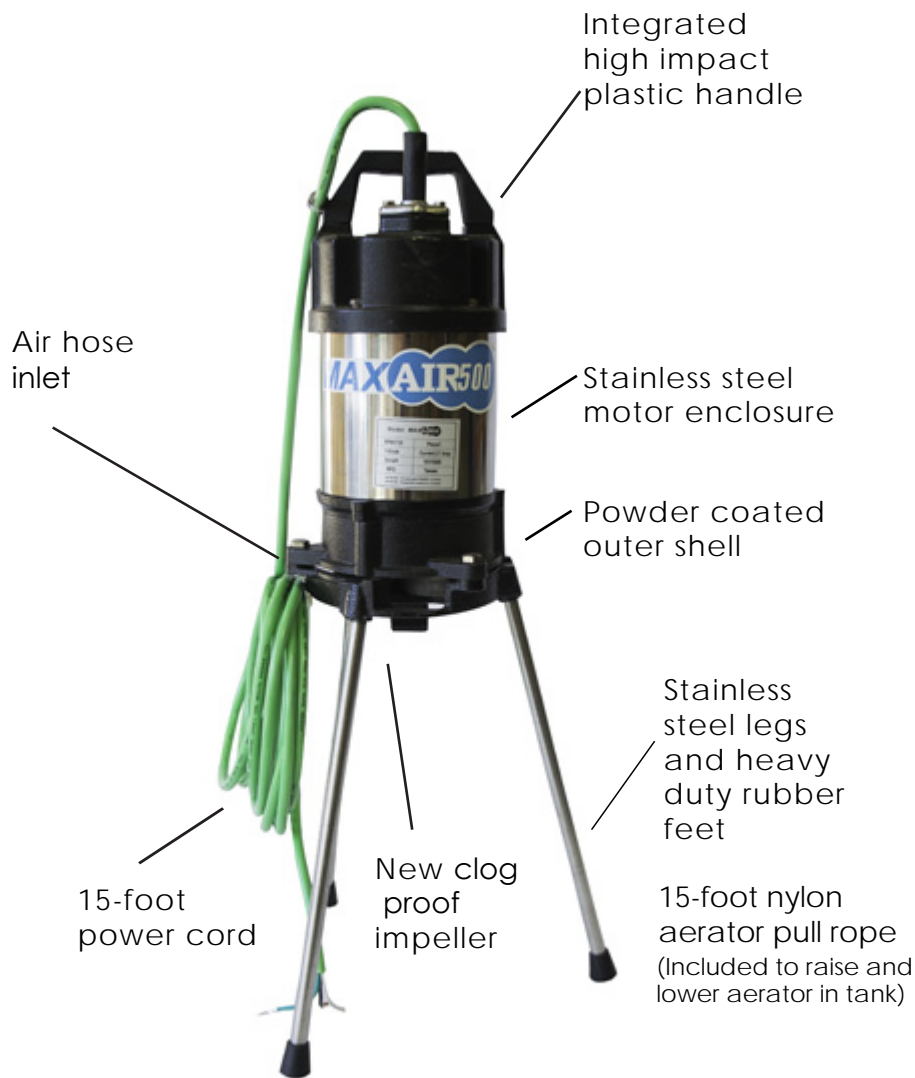

Features

- Low rpm, high torque motor fully enclosed continuous duty
- Thermo overload protected
- Stainless steel motor enclosure & legs
- 15-foot power cord
- 1/2" FPT air hose inlet

The MAXAIR500 submersible aerator is a compatible replacement for the Multi-Flo/EnviroGuard* aerator manufactured to meet or exceed industry standards on performance and reliability.

**MAX Filters™
30 Pack**



Used in a Multi-Flo/EnviroGuard* tank



The MAXAIR500 Submersible Aerator has been independently tested for performance in original manufacturer's tanks and proven to meet or exceed the oxygen transfer rates of original manufacturer's aerator units.

Order/Questions :

800-778-1540 or 636-583-1608

Septic Tank Parts

MAXAIR500TM SUBMERSIBLE AERATOR

The industrial grade factory built MAXAIR500TM aerator has been engineered to meet or exceed industry standards and has been put through rigorous testing in the lab and field to ensure that the MAXAIR500 will provide years of dependable service.

Features

- Air hose inlet: 1/2" FPT
- Low rpm, high torque fully enclosed continuous duty motor
- Stainless steel motor enclosure & legs with heavy duty rubber feet
- Integrated high impact plastic handle
- Powder coated outer shell
- 15-foot power cord
- 15-foot nylon pull rope

Specifications

Amps	2.7
Volts	115 single phase Thermal protected
RPM	1725
Air Hose Inlet	1/2" FPT
Unit Dims	25" x 12" Unit Wt
	32 lbs.

Unit Dimensions

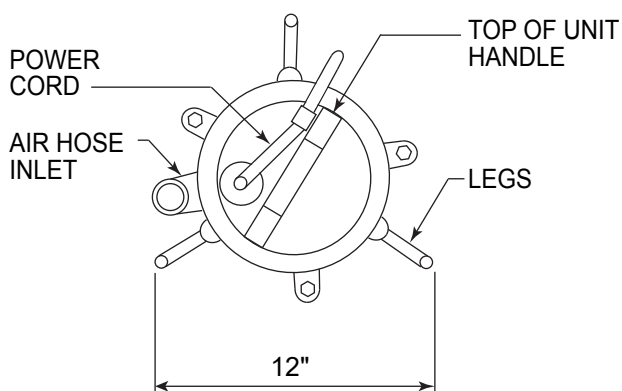

TOP VIEW DIAGRAM

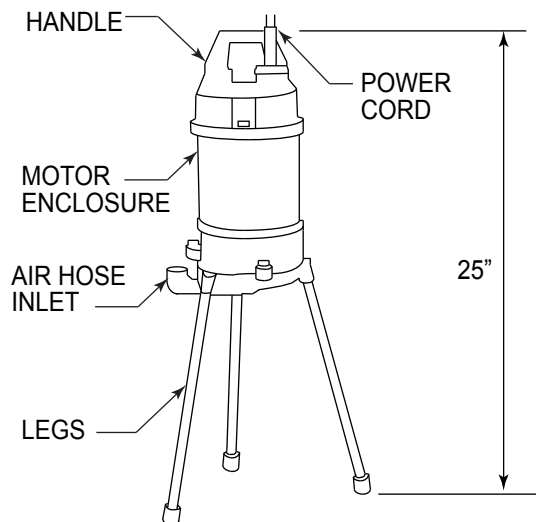

SIDE VIEW DIAGRAM

*All original manufacturer's names, drawings, and part numbers are used for identification purposes only and we are in no way implying that any of our products are original equipment parts. Multi-Flo/EnviroGuard is a registered trademark of Consolidated Treatment Systems, Inc.

Septic Tank Parts reserves the right under its product improvement policy to change construction or design detail without obligation regarding previous models and to furnish equipment when so altered without reference to illustrations or specifications used here.

Septic Tank Parts • 7059 Hwy 47 (shipping) P.O. Box 632 (mail) • Union, Missouri 63084 • Tel: 800-778-1540 Fax 636-583-6432 • sales@septic-tank-parts.com

Copyright © Septic Tank Parts 2018

www.septic-tank-parts.com • www.maxair500.com

All rights reserved.